

im | 09



Guidovia | Incastellatura | Gancere
Overhead rail | Framework | Hooked bars



E' da oltre 50 anni che la ITALMODULAR contribuisce con passione, tecnologia, qualità ed affidabilità ad organizzare e migliorare il modo di lavorare di uomini e aziende. Una realtà produttiva che si è sempre proposta come partner affidabile nel progettare soluzioni e sistemi modulari ad alto contenuto innovativo per razionalizzare ed organizzare gli spazi di stoccaggio all'interno di ogni ambiente lavorativo. L'esperienza maturata, i continui investimenti in tecnologia e risorse umane, il servizio di assistenza a livello internazionale, permettono oggi all'azienda di proporsi come valido punto di riferimento quando fattori come innovazione, qualità e servizio diventano indispensabili. Un complesso di grande efficienza che guida le sue esperienze verso soluzioni innovative a totale affidabilità in grado di rispondere, sempre e bene, alle più diversificate esigenze di ogni cliente.

For over 50 years ITALMODULAR have been helping companies and their people organize and improve the way they work, with an injection of passion, technology, quality and reliability. This is a business that has unfailingly offered its services to customers as a reliable partner in designing highly innovative modular systems and solutions to rationalize and organize storage space within any workplace. Due to the experience gained, their continuous investments in technology and human resources and their international customer support service, the company now emerges as a solid benchmark wherever factors such as innovation, quality and service are of the essence. A highly efficient combination that steers Italmodular's efforts towards innovative and totally reliable solutions capable of consistently meeting and exceeding the many and varied demands of each customer.





Assemblaggio senza l'ausilio di attrezzi speciali
Assembly without need for special tools



Veloce da assemblare
Quick to assemble



Realizzato su progetto
Option of custom design



Prodotto standard
Standard product



Portata massima Kg/m
Maximum load capacity kg/m



Adatto per ambienti refrigerati
Suitable for refrigerated rooms



Alluminio anodizzato
Anodized aluminium



Garanzia
Warranty



Imballaggio termoretrato
Heat shrink wrapping



Materiale riciclabile
Recyclable material

im | 09



Guidovia | Incastellatura | Gancere

Guidovie, incastellature e gancere del sistema IM 09 rappresentano la soluzione ideale per trasportare, agganciare e stivare le carni all'interno di celle frigorifere di qualsiasi tipo e dimensione.

Interamente realizzate in lega di alluminio anodizzato 12 micron e materiali plastici atossici garantiscono inalterabilità nel tempo ed un elevato standard di igiene. Un sistema componibile stabile, solido, facile e veloce da installare che consente una grande adattabilità alle più svariate esigenze di spazio.

pag. 6 | Guidovia

pag. 14 | Incastellatura

pag.18 | Gancere

Overhead rail | Framework | Hooked bars

The IM 09 system overhead rails, frames and hooked bars are the ideal solution for transporting, hanging up and storing meat inside walk-in cold rooms of any kind and size. Made entirely from anodized aluminium alloy 12 microns thick and non-toxic plastics, they are guaranteed to offer lasting stability and a high standard of hygiene. A stable, solid sectional system that is quick and easy to install and shows great adaptability, allowing it to cater to a diversity of space requirements.

page 6 | Overhead rail

page 14 | Framework

page 18 | Hooked bars



Guidovia
Overhead rail



Il trasporto delle carni a scorrimento fluido, silenzioso, pratico e sicuro.

La guidovia IM 09 è il sistema componibile che rappresenta la soluzione ideale per attrezzare il moderno reparto macelleria ed è particolarmente indicata per agganciare, trasportare e stivare la carne all'interno di celle frigorifere e locali di lavorazione. I vantaggi che offre sono economia di installazione, elevata praticità d'uso e sicurezza d'igiene garantita dall'uso di alluminio anodizzato e materiali plastici atossici. Un sistema componibile stabile, solido, resistente al carico ed alle sollecitazioni dotato di uno scorrimento fluido e silenzioso.

Semplice e veloce nel montaggio questo sistema, completo di accessori che permettono una libera composizione dell'impianto, assicura una grande adattabilità alle più svariate necessità.

Inoltre il nuovo sistema con **scambio a tre vie brevettato** dalla Italmodular consente di spostare la carne nelle tre direzioni con estrema semplicità lavorando in massima praticità e sicurezza eliminando le perdite di tempo ad ogni cambio di direzione.



Practical and safe meat transport with smooth, quiet gliding action.

The IM 09 sectional overhead rail system is the ideal solution for fitting out modern butchery departments and is particularly suitable for hanging up, transporting and storing meat inside walk-in refrigerators and processing rooms. The advantages that come with the system are time-saving installation, highly practical use and hygienic safety guaranteed by the use of anodized aluminium and non-toxic plastics.

A sectional, stable, solid system that is built to take the loads and strain, featuring smooth, noiseless gliding. Quick and simple to assemble, this system - complete with accessories allowing system components to be put together at will - provides great adaptability to a whole host of different needs.

*Moreover, the new **three-way switch system patented** by Italmodular means meat can be moved effortlessly in three directions, providing operators with a supremely practical and safe work space, at the same time eliminating the time wasting associated with changing direction.*





Il sistema componibile ideale
per trasportare ed agganciare.

*Ideal sectional system
for transporting and hanging.*

Facile e veloce da montare.

Semplice, veloce nel montaggio e completo di accessori che permettono una libera composizione dell'impianto, questo sistema offre economia di installazione ed una grande adattabilità alle singole necessità applicative.

Quick and easy to assemble.

Quick and simple to assemble, this system - which comes complete with accessories allowing system components to be put together at will - offers the advantage of time-saving installation and great adaptability to individual application needs.

Un sistema igienicamente sicuro.

Interamente realizzato in lega di alluminio anodizzato 12 micron e materiali plastici atossici garantisce inalterabilità nel tempo contro la corrosione da acqua e umidità ed un elevato standard d'igiene.

A hygienically safe system.

Made entirely from anodized aluminium alloy 12 microns thick and non-toxic plastics, it is guaranteed to offer lasting stability against corrosion by water and moisture and a high standard of hygiene.





Alta resistenza al carico, stabile, silenzioso.

Un sistema componibile resistente al carico ed alle sollecitazioni, stabile, solido e con uno scorrimento dei ganci fluido e silenzioso.

High load resistance, stable, quiet.

A stable, solid sectional system that is built to take the loads and strain, featuring hooks that glide smoothly and noiselessly.



Elevata praticità d'uso.

Il sistema di scambio a tre vie brevettato dalla Italmodular consente di spostare la carne nelle tre direzioni con estrema semplicità lavorando in massima praticità e sicurezza eliminando le perdite di tempo ad ogni cambio di direzione.

Highly practical to use.

The three-way switch system patented by Italmodular means meat can be moved effortlessly in three directions, providing operators with a supremely practical and safe work space, at the same time eliminating the time wasting associated with changing direction.



Ripiano Grigliato. Ripiano in alluminio da fissare alle piantane. Può essere fisso o ribaltabile.
Rack. Aluminium shelf to be attached to uprights. Can be fixed or hinged.

Code 09.FIG



Deviazione Angolata. Permette di deviare il percorso della guidovia con angolazione variabile da 0° a 45°.

Angle Divert Switch. Used to divert the path of the overhead rail with an angle varying in the range 0 to 45°.

Code 09.00350



Discesa Guidovia manuale. Permette il collegamento tra guidovie di diverso livello. Costruita in alluminio anodizzato, viene personalizzata a seconda delle inclinazioni e dislivelli.

Manual Overhead Rail Lowering system. Used to connect overhead rails at different heights. Made from anodized aluminium, it is customized depending on the angle and difference in level.

Code 09.00470



Inseritore Carrucole. Installato all'estremità della guidovia IM 09, facilita l'estrazione e l'inserimento delle carrucole. Struttura in fusione di alluminio.

Pulley Connector. Installed on the end of the IM09 overhead rail, it helps with removing and inserting pulleys. Cast aluminium structure.

Code 09.00365

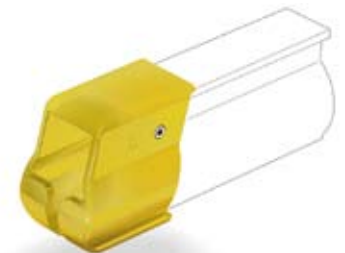

Fermo Blocca Carrucola. Fermo meccanico in acciaio inox per bloccare la carrucola e permettere la lavorazione della carne.

Pulley Stop. Stainless steel mechanical stop for holding the pulley in place so that the meat can be processed.

Code 09.01080



Taglio Termico Anticondensa. Installato in prossimità della porta della cella frigorifera, interrompe la conduzione termica dei metalli, riducendo la formazione di condensa.

Realizzato in materiale plastico.

Anti-Condensation Thermal Break. Installed near the walk-in cold room door, it impedes the heat conduction of metals, reducing the formation of condensation. Made from plastic.

Code 09.00420



Taglio Termico Portante Anticondensa. Installato in prossimità della porta della cella frigorifera, interrompe la conduzione termica dei metalli, riducendo la formazione di condensa ed evitando le strutture di sostegno a ridosso della porta. Realizzato in materiale plastico.

Anti-Condensation Load-Bearing Thermal Break. Installed near the walk-in cold room door, it impedes the heat conduction of metals, reducing the formation of condensation and doing away with the need for supporting structures up against the door. Made from plastic.

Code 09.00425

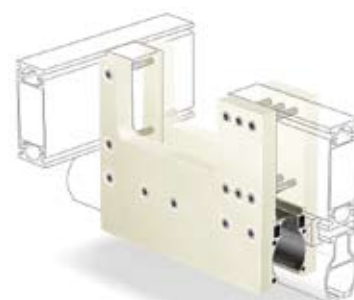

Snodo Orizzontale a molla per guidovia. Permette l'interruzione della guidovia in prossimità di porte scorrevoli. Struttura in acciaio zincato. L'azionamento dello snodo è effettuato dalla porta.

Spring-loaded Horizontal Joint for overhead rail. Enables a break to be introduced in the overhead rail by sliding doors. Galvanized steel structure. The joint is operated by the door.

Code 09.00430

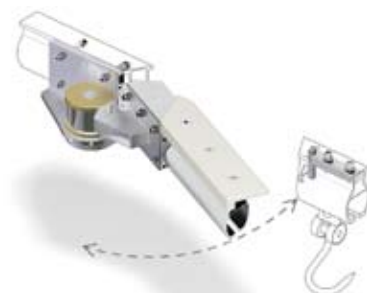

Snodo Autolivellante per guidovia. Funzionamento manuale, rotazione verticale, ingombro contenuto (~300 mm), utilizzato in prossimità di porte sezionali, serrande avvolgibili, montacarichi, ecc.

Self-Levelling Joint for overhead rail. Manual operation, vertical rotation, small size (~300 mm), used near sectional doors, roll-up shutters, goods lifts, etc.

Code 09.00460



Snodo Verticale per scarico e carico. Lo snodo è portante e permette di estendere la guidovia del punto di carico di circa 850 mm. La rotazione è manuale. Struttura in acciaio zincato.

Vertical Joint for unloading and loading. The joint is load-bearing and allows the overhead rail to be lifted by approx. 850 mm at the loading point. It is rotated manually. Galvanized steel structure.

Code 09.00450

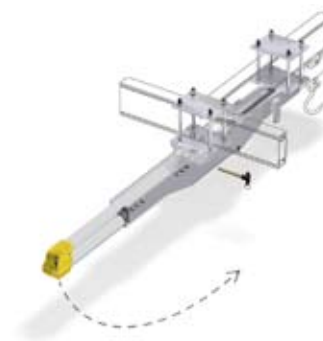

Pesa Elettronica P.E. 300. Precisione 1/3000. Portata 300 Kg., divisione 100 g. Visualizzazione del peso digitale. Tensione di alimentazione 220 V, 50 Hz. Tratto di pesatura 300 mm. Struttura in acciaio zincato.

Electronic Scale P.E. 300. Resolution 1/3000. Capacity 300 kg, division 100 g. Digital weight display. Power supply 220 V, 50 Hz. Weighing section 300 mm. Galvanized steel structure.

Code 09.00300



Paranco Elettrico. Paranco elettrico a catena. Portate standard 125/250/500 Kg. Completo di raccogli catena, quadro elettrico B.T. con pulsantiera. Motore 380 V, 50 Hz.

Electric Hoist. Electric chain hoist. Standard capacities 125/250/500 kg. Complete with chain container, low voltage control board with pushbutton panel. Motor 380 V, 50 Hz.

Code 4.001009 | 4.001010 | 4.001020



Attacco fisso per paranco.
Fixed fitting for hoist.

Code 09.00480

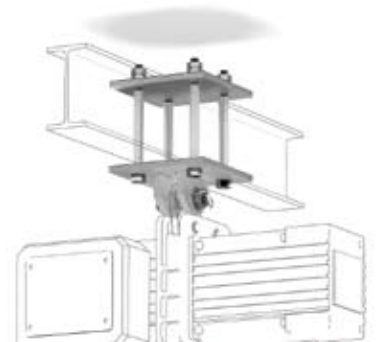

Carrello a spinta per paranco.
Manually operated runner for hoist.

Code 4.001100

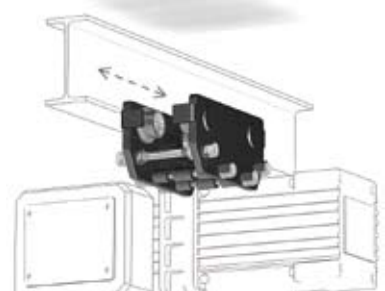

Gancio inox per paranco.
Stainless steel hook for hoist.

Code 7.000231



Discensore Automatico Elettrico. Permette di sollevare o abbassare carichi appesi alla carrucola. La portata nominale è di 200 Kg. Motore 380 V, 50 Hz, 0,45 Kw. Quadro elettrico B.T. con pulsantiera. Struttura in acciaio zincato. Massimo ingombro in altezza da sotto guidovia 650 mm.

Automatic Electric Lowerator. Enables loads hung on the pulley to be lifted or lowered. Nominal capacity is 200 kg. Motor 380 V, 50 Hz, 0.45 kW. Low voltage control board with pushbutton panel. Galvanized steel structure. Maximum overall height under overhead rail is 650 mm.

Code 2.02570



Trasportatore a Catena Elettrico. Permette il collegamento tra guidovie di diverso livello. Il dislivello varia da un minimo di 300 mm ad un massimo di 1500 mm. Portata 350 Kg/m, Motore 380 V, 50 Hz, 0,75 Kw. Struttura in acciaio zincato.

Electric chain conveyor. Used to connect overhead rails at different heights. Difference in height ranges from at least 300 mm to no more than 1500 mm. Capacity 350 kg/m, Motor 380 V, 50 Hz, 0.75 kW. Galvanized steel structure.

Code 09.01050



Tratto Guidovia Mobile Pneumatico. Permette lo spostamento verticale di un tratto di guidovia (lunghezza di circa 2,5 m), favorendo il passaggio di muletti, carrelli, ecc.

Pneumatic Mobile Overhead Rail Section. Enables a section of overhead rail (approx. 2.5 m long) to be moved vertically so as to provide enough clearance for lift trucks, trolleys, etc. to move underneath.

Code 09.00520



Divaricatore Elettrico. Ideale per facilitare la seziona tura dei bovini e suini. Motore elettrico 380 V, 50 Hz, 1 Kw. Quadro elettrico B.T. con pulsantiera. Dimensioni: Lunghezza 1700 mm (apertura 1500).

Electric Spreader. Ideal to make the job of cutting up the carcasses of cattle and pigs easier. Electric motor 380 V, 50 Hz, 1 kW. Low voltage control board with pushbutton panel. Dimensions: Length 1700 mm (opening 1500).

Code 8.004022

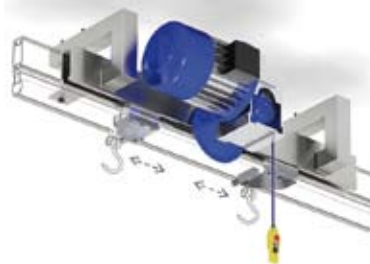

Braccio Idraulico per scarico e carico. Consente lo scarico ed il carico delle carni fresche dagli automezzi alla guidovia. Struttura in alluminio Anticorodal. Ancoraggi personalizzati. Funzionamento servo-assistito con centralina idraulica incorporata. Quadro elettrico B.T. Portata max. 150 Kg, motore elettrico 380/220 V, 50 Hz, 0,8 Kw, raggio di lavoro 2260 mm, angolo di rotazione 270° ed escursione verticale 2000 mm.

Hydraulic Arm for unloading and loading. Enables unloading and loading of fresh meat between vehicles and the overhead rail system. Anticorodal aluminium structure. Customized fixings. Servo-assisted operation with built-in hydraulic power pack. Low voltage control board. Max. capacity 150 kg, electric motor 380/220 V, 50 Hz, 0.8 kW, working range 2260 mm, angle of rotation 270° and vertical travel 2000 mm.

Code 8.004150





Incastellatura

Framework





Il sistema componibile per agganciare e stivare.

L'incastellatura autoportante del sistema IM 09, certificata con marchio NF, rappresenta la soluzione ideale e funzionale per agganciare e stivare le carni all'interno di celle frigorifere di qualsiasi tipo e dimensione senza la necessità di dover forare i pannelli. Costituita da profili in lega di alluminio anodizzato 12 micron e componenti intercambiabili ed adattabili tra di loro, questo sistema permette di comporre liberamente l'incastellatura adattandola alle proprie esigenze. Un sistema moderno, stabile, solido, facile e veloce nel montaggio, idoneo al contatto con alimenti secondo le normative vigenti in materia.

Sectional system for hanging and storing.

The IM 09 system self-supporting framework, which is certified with NF marking, is a functional solution that is ideal for hanging up and storing meat inside walk-in cold rooms of any kind and size without the need for making holes in panels.

Comprising anodized aluminium alloy profiles 12 microns thick and components that can be swapped round and adapted to each other, this system is designed to give you unlimited freedom in putting together the framework to meet your individual needs. A modern, stable, solid system that is quick and easy to assemble and food safe according to the relevant regulations in force.





La soluzione stabile, solida e moderna
per agganciare e stivare

*Stable, solid, modern system
for hanging and storing*

Garantita nel tempo.

Interamente realizzata in lega di alluminio anodizzato 12 micron e materiali plastici atossici garantisce inalterabilità nel tempo contro la corrosione da acqua e umidità.

Guaranteed to last.

Made entirely from anodized aluminium alloy 12 microns thick and non-toxic plastics, it is guaranteed to offer lasting stability against corrosion by water and moisture.

Alta resistenza al carico, stabile, sicuro

Un sistema componibile moderno, resistente al carico, stabile, solido e che non necessita di fissaggi o ancoraggi particolari all'interno delle celle frigorifere.

High load resistance, stable, safe.

A modern, stable and solid sectional system that is built to take heavy loads and does not need any special fastening or anchoring inside walk-in cold rooms.





Semplice e veloce da montare.

L'estrema semplicità di montaggio ottenuta grazie al sistema ad incastro permette un assemblaggio semplice e veloce senza l'ausilio di attrezzi speciali.

Quick and simple to assemble.

The extreme simplicity of assembly achieved thanks to the slot-together system means assembly is straightforward and fast and can be performed without the aid of special tools.



Standard d'igiene elevato.

Le superfici lisce ed arrotondate, i profili chiusi, la totale assenza di spazi e fessure dove possa annidarsi lo sporco garantiscono un elevato standard di igiene.

High standard of hygiene.

The smooth, rounded surfaces, the closed profiles and the total absence of gaps and cracks in which dirt can lurk combine to deliver a high standard of hygiene.

Un sistema componibile personalizzabile in qualsiasi misura.

Il sistema per la sua grande versatilità permette una composizione libera all'interno di celle frigorifere di qualsiasi tipo e dimensione.

A sectional system that can be tailored to any size.

The system boasts impressive versatility meaning different compositions can be put together at will inside walk-in cold rooms of any kind and size.





im|09



Gancere
Hooked bars





Gancera a soffitto. Portata 50÷200 kg/m
Ceiling-mounted hooked bar. Load capacity 50÷200 kg/m

Soluzioni adattabili da parete o a soffitto, fisse o scorrevoli.

Le gancere del sistema IM 09 rappresentano la soluzione ideale per completare ed attrezzare l'arredamento di macellerie, salumerie e supermercati. Realizzate con profili in lega di alluminio anodizzato di diverse misure per varie portate di carico, la gamma comprende ganci scorrevoli o fissi in acciaio inox e in materiale plastico atossico. I diversi tipi di staffa consentono inoltre l'installazione delle gancere a parete o a soffitto e fisse o scorrevoli a secondo delle specifiche esigenze.

Adaptable wall-or ceiling-mounted, fixed or sliding solutions.

The IM 09 system hooked bars make an ideal solution for fitting out and adding the finishing touch to butchers' shops, delicatessens and supermarkets. Made with anodized aluminium alloy profiles in various sizes for different load capacities, the range includes sliding or fixed hooks made from stainless steel and non-toxic plastic. The various bracket options also mean the hooked bars can be installed on a wall or ceiling and can be fixed or sliding to suit the specific requirements.





Gancera su piantane. Portata 50÷200 kg/m | Hooked bar mounted on uprights. Load capacity 50÷200 kg/m

La soluzione ideale per completare l'arredamento
di macellerie, salumerie e supermercati
*Ideal solution for adding the finishing touch
to butchers' shops, delicatessens and supermarkets*



Gancera a parete. Portata 50÷200 kg/m
Wall-mounted hooked bar. Load capacity 50÷200 kg/m

Garantite nel tempo.

Interamente realizzate in lega di alluminio anodizzato e materiali plastici atossici garantiscono inalterabilità nel tempo contro la corrosione da acqua e umidità.

Guaranteed to last.

Made entirely from anodized aluminium alloy and non-toxic plastics, they are guaranteed to offer lasting stability against corrosion by water and moisture.



Gancera a parete leggera. Portata 60 kg/m
Light wall-mounted hooked bar. Load capacity 60 kg/m



Un sistema personalizzabile in qualsiasi misura.

Il sistema per la sua grande versatilità permette una composizione libera nell'arredamento di macellerie, salumerie e supermercati in diverse misure per varie portate di carico.

A system that can be tailored to any size.

The system boasts impressive versatility meaning different compositions can be put together at will to fit out butcher's shops, delicatessens and supermarkets in various sizes for different load capacities.



Semplici e veloci da montare.

L'estrema semplicità di montaggio ottenuta grazie ai sistemi ad incastro permette un assemblaggio semplice e veloce senza l'ausilio di attrezzi speciali.

Quick and simple to assemble.

The extreme simplicity of assembly achieved thanks to the slot-together systems means assembly is straightforward and fast and can be performed without the aid of special tools

Standard d'igiene elevato e sicuro.

Le superfici lisce ed arrotondate, i profili chiusi, la totale assenza di spazi e fessure dove possa annidarsi lo sporco garantiscono un elevato standard di igiene.

Safe, high standard of hygiene.

The smooth, rounded surfaces, the closed profiles and the total absence of gaps and cracks in which dirt can lurk combine to deliver a high standard of hygiene.



Gancera scorrevole a parete. Portata 50÷300 kg/m
Wall-mounted sliding hooked bar. Load capacity 50÷300 kg/m



Gancera scorrevole a soffitto. Portata 50÷300 kg/m
Ceiling-mounted sliding hooked bar. Load capacity 50÷300 kg/m



Marchio NF Igiene Alimentare Assegnato da:

AFAQ-AFNOR CERTIFICATION

11, Av. Francis de Pressensè

93571 Saint-Denis la Plaine Cedex - F -

Questo marchio certifica la conformità secondo il riferimento NF 031

Caratteristiche certificate:

- Attitudine alla pulizia

NF Food Hygiene Label assigned by:

AFAQ-AFNOR CERTIFICATION

11, Av. Francis de Pressensè

93571 Saint-Denis la Plaine Cedex - F -

This label certifies that the product is manufactured in accordance with norm NF 031

It certifies that:

- The product is suitable in terms of hygiene

Garanzia | Warranty

La garanzia si limita ai componenti che presentano difetti di fabbricazione e contro la corrosione da acqua e umidità.

La garanzia non avrà valore per danni causati da un uso improprio e/o negligenza dell'utilizzatore, da eventuali sovraccarichi di peso, da agenti atmosferici, dall'uso di prodotti chimici, acidi e sale.

La garanzia non comprende il trasporto dei componenti di ricambio e la mano d'opera di eventuale tecnico.

Warranty coverage is limited to parts showing defects in materials and workmanship or affected by corrosion by water and moisture.

The warranty shall not be valid for damage caused by improper use and/or carelessness by the user, by overloading, by atmospheric agents, by the use of chemicals, acids and salt.

The warranty does not include the shipping of spare parts and the labour of technical personnel whose work may be required.



26025 Pandino (CR) Italy
Via De Gasperi, 25
Tel. +39 0373 970296 / 970184
Fax +39 0373 970329
www.italmodular.com
info@italmodular.com

Rivenditore autorizzato:
Authorized dealer:
